

IEEE Trial-Use Guide for Accelerated Aging Tests for Medium-Voltage Extruded Electric Power Cables Using Water-Filled Tanks

Sponsor

**Insulated Conductors Committee
of the
IEEE Power Engineering Society**

Approved 14 October 1998

IEEE-SA Standards Board

Abstract: Accelerated aging tests on extruded medium-voltage cables using water-filled tanks are addressed. Information on the equipment, cable samples, test conditions, and measurements to perform the aging tests is provided. Techniques on how to analyze the test data are also included. The implementation of this guide will allow a better description of the test data obtained by different laboratories.

Keywords: accelerated cable life test (ACLT), accelerated aging test, cross-linked polyethylene (XLPE), ethylene propylene rubber (EPR), medium-voltage cable, tank structure, temperature measurement and profile, test conditions, water-filled tanks

The Institute of Electrical and Electronics Engineers, Inc.
345 East 47th Street, New York, NY 10017-2394, USA

Copyright © 1999 by the Institute of Electrical and Electronics Engineers, Inc.
All rights reserved. Published 7 April 1999. Printed in the United States of America.

Print: ISBN 0-7381-1573-8 SH94681
PDF: ISBN 0-7381-1574-6 SS94681

No part of this publication may be reproduced in any form, in an electronic retrieval system or otherwise, without the prior written permission of the publisher.

IEEE Standards documents are developed within the IEEE Societies and the Standards Coordinating Committees of the IEEE Standards Association (IEEE-SA) Standards Board. Members of the committees serve voluntarily and without compensation. They are not necessarily members of the Institute. The standards developed within IEEE represent a consensus of the broad expertise on the subject within the Institute as well as those activities outside of IEEE that have expressed an interest in participating in the development of the standard.

Use of an IEEE Standard is wholly voluntary. The existence of an IEEE Standard does not imply that there are no other ways to produce, test, measure, purchase, market, or provide other goods and services related to the scope of the IEEE Standard. Furthermore, the viewpoint expressed at the time a standard is approved and issued is subject to change brought about through developments in the state of the art and comments received from users of the standard. Every IEEE Standard is subjected to review at least every five years for revision or reaffirmation. When a document is more than five years old and has not been reaffirmed, it is reasonable to conclude that its contents, although still of some value, do not wholly reflect the present state of the art. Users are cautioned to check to determine that they have the latest edition of any IEEE Standard.

Comments for revision of IEEE Standards are welcome from any interested party, regardless of membership affiliation with IEEE. Suggestions for changes in documents should be in the form of a proposed change of text, together with appropriate supporting comments.

Interpretations: Occasionally questions may arise regarding the meaning of portions of standards as they relate to specific applications. When the need for interpretations is brought to the attention of IEEE, the Institute will initiate action to prepare appropriate responses. Since IEEE Standards represent a consensus of all concerned interests, it is important to ensure that any interpretation has also received the concurrence of a balance of interests. For this reason, IEEE and the members of its societies and Standards Coordinating Committees are not able to provide an instant response to interpretation requests except in those cases where the matter has previously received formal consideration.

Comments on standards and requests for interpretations should be addressed to:

Secretary, IEEE-SA Standards Board
445 Hoes Lane
P.O. Box 1331
Piscataway, NJ 08855-1331
USA

<p>Note: Attention is called to the possibility that implementation of this standard may require use of subject matter covered by patent rights. By publication of this standard, no position is taken with respect to the existence or validity of any patent rights in connection therewith. The IEEE shall not be responsible for identifying patents for which a license may be required by an IEEE standard or for conducting inquiries into the legal validity or scope of those patents that are brought to its attention.</p>

Authorization to photocopy portions of any individual standard for internal or personal use is granted by the Institute of Electrical and Electronics Engineers, Inc., provided that the appropriate fee is paid to Copyright Clearance Center. To arrange for payment of licensing fee, please contact Copyright Clearance Center, Customer Service, 222 Rosewood Drive, Danvers, MA 01923 USA; (978) 750-8400. Permission to photocopy portions of any individual standard for educational classroom use can also be obtained through the Copyright Clearance Center.

Introduction

(This introduction is not part of IEEE Std 1407-1998, IEEE Trial-Use Guide for Accelerated Aging Tests for Medium-Voltage Extruded Electric Power Cables Using Water-Filled Tanks.)

This guide addresses accelerated aging tests of extruded medium-voltage cables using water-filled tanks. Information is provided on the equipment, cable samples test conditions, and measurements to perform the accelerated aging tests. The guide identifies the critical test parameters and describes techniques for their measurement and control. The implementation of the techniques will allow test data obtained by different laboratories at different times to be better compared. Specific test values (e.g., maximum temperature and voltage) have not been included in this version of the guide, but may be recommended in future revisions.

The work of preparing this guide was carried out by Task Force 12-35 of the Tests and Measurements Subcommittee 12 of the Insulated Conductors Committee of the IEEE Power Engineering Society. At the time this guide was approved, the task force had the following membership:

John Densley, Chair

Bruce S. Bernstein
Willem Boone
Ray O. Bristol
Paul L. Cinquemani
Jim Fitzgerald
Larry H. Gross
Rick A. Hartlein

Stanley R. Howell
Huixin Hu
Darrell R. Jeter
Carlos Katz
Glenn J. Luzzi
Harry E. Orton
John Pegram

Serge Péliou
Haridoss Sarma
John T. Smith, III
Robert Smith
Frank Stepniak
Bill Temple
Mark D. Walton

The following members of the balloting committee voted on this standard:

Torben Aabo
Thamir J. Al-Hussaini
William O. Andersen, Jr.
Thomas P. Arnold
Theodore A. Balaska
Martin Baur
Thomas M. Black
David T. Bogden
Kent W. Brown
Thomas C. Champion
Paul L. Cinquemani
James M. Daly
John Densley
Claus Doench
Robert M. Eichhorn
John S. Engelhardt
Michael S. Foty
Ronald F. Frank
Kenneth Hancock
Richard L. Harp

V. Stan Harper
Wolfgang B. Haverkamp
Stanley V. Heyer
Stanley R. Howell
Richard Huber
Carlos Katz
Lawrence J. Kelly
Frank Kuchta
Carl Landinger
Jack Lasky
Jack Lawson
Gabor Ludasi
Glenn J. Luzzi
John M. Makal
Spiro G. Mastoras
E. J. McGowan
John E. Merando, Jr.
Shantanu Nandi
Harry E. Orton

Arthur V. Pack
Serge Péliou
Gary Polhill
Dennis C. Pratt
Paul F. Pugh
Robert A. Resuali
Hazairin Samaulah
Ralph W. Samm
Joseph H. Snow
Henry J. Soleski
Nagu N. Srinivas
Mike D. Sweat
John Tanaka
Austin C. Tingley
Edward Walton
Daniel J. Ward
J. Nick Ware
Roland H. W. Watkins
William D. Wilkens
Joseph T. Zimnoch

The final conditions for approval of this standard were met on 14 October 1998. This standard was conditionally approved by the IEEE-SA Standards Board on 16 September 1998, with the following membership:

Richard J. Holleman, *Chair*

Donald N. Heirman, *Vice Chair*

Judith Gorman, *Secretary*

Satish K. Aggarwal
Clyde R. Camp
James T. Carlo
Gary R. Engmann
Harold E. Epstein
Jay Forster*
Thomas F. Garrity
Ruben D. Garzon

James H. Gurney
Jim D. Isaak
Lowell G. Johnson
Robert Kennelly
E. G. "Al" Kiener
Joseph L. Koepfinger*
Stephen R. Lambert
Jim Logothetis
Donald C. Loughry

L. Bruce McClung
Louis-François Pau
Ronald C. Petersen
Gerald H. Peterson
John B. Posey
Gary S. Robinson
Hans E. Weinrich
Donald W. Zipse

*Member Emeritus

Kim Breitfelder
IEEE Standards Project Editor

Contents

1. Overview.....	1
1.1 Scope.....	2
2. References.....	3
3. Definitions, abbreviations, and acronyms.....	3
3.1 Definitions.....	3
3.2 Abbreviations and acronyms.....	3
4. Test specimens	4
5. Prior tests and preconditioning of specimens	5
6. Test structure.....	8
7. Temperature	12
7.1 Test sample conductor temperature	12
7.2 Water temperature.....	16
7.3 Ambient temperature in the test area	17
7.4 Establishing a temperature profile	17
7.5 Monitoring/controlling temperatures during the ACLT	18
7.6 Temperature measurement techniques.....	18
8. Water.....	19
9. Voltage.....	20
10. Test matrix	22
11. Failure	23
12. Abnormalities.....	24
13. Diagnostics.....	25
14. Data analysis	26
15. Final report.....	27
16. Conclusions.....	27
Annex A (informative) Final report	28
Annex B (informative) Bibliography	30

IEEE Trial-Use Guide for Accelerated Aging Tests for Medium-Voltage Extruded Electric Power Cables Using Water-Filled Tanks

1. Overview

The insulations commonly used in extruded power cables are cross-linked polyethylene (XLPE), tree-retardant XLPE (TRXLPE), and ethylene propylene rubber (EPR). These materials are known to gradually deteriorate with time due to the synergistic action of moisture and electrical stress. This degradation causes a reduction in the breakdown voltage and an increase in the dielectric loss. The degradation can be so severe that failures can occur in service at operating stresses. The mechanisms of moisture-induced degradation have been studied extensively and it is believed that several mechanisms are occurring. A thorough knowledge of the degradation mechanisms allows optimum choices of test parameters to be made; this results in an accelerated aging test that evaluates the long-term performance of a cable in the absence of scattered defects. Although there is not a complete understanding of the mechanisms of moisture-induced degradation, the urgency to develop an aging test has resulted in the proposal of several accelerated aging tests for materials and cables (Banks, et al., [B4],¹ Bartnikas, Densley, and Eichhorn [B5], Bartnikas, et al., [B6], Mashikian, et al., [B21], Schroth, et al., [B24], Steenish and Faremo [B26]). A problem inherent in all accelerated aging tests is the choice of test parameters in the test itself. These should contain the deterioration factors causing service aging and not introduce aging mechanisms that do not occur in service. The diagnostic test must measure a property representative of service aging. Research has shown that the most important parameters in tests to evaluate moisture-induced degradation are electrical stress, temperature, water characteristics, and time.

One accelerated aging test that has evolved in North America into a qualification test is the accelerated water treeing test in which lengths of cables are aged in water-filled pipes for 4, 6, and 12 months and then subjected to a step ac breakdown test, the diagnostic test (AEIC CS5-94, AEIC S6-96). An alternative test has emerged where cables are aged either for a fixed time or to failure in water-filled tanks, i.e., an accelerated cable life test (ACLT) (Lyle [B19], Walton, et al., [B29]). The time-to-failure test has the advantage of involving the whole aging process, initiation, growth, and final failure. The main disadvantage is that the test duration is unknown and there can be considerable time between the first and the last failure. Several laboratories have performed and are now performing tank-type tests using different aging conditions of voltage, temperature, water characteristics, etc. This makes a direct comparison of the data between laboratories very difficult. The situation is further complicated because the methods of measuring some of the critical parame-

¹The numbers in brackets correspond to those of the bibliography in Annex B.

ters differ significantly. As a result, apparently similar test conditions can, in fact, be entirely different in two separate test arrangements. An example of this ambiguity is the temperature measurement. Although a nominal temperature of 90 °C is sometimes used as the maximum temperature during temperature cycling, the precise location where this temperature is measured may vary. It can be measured in the length of the cable outside the water or in the length of cable immersed in the water. If the water temperature is not controlled, however, the temperature of the immersed cable will depend upon the following:

- Tank size
- Shape and material
- Volume of water
- Number of cables in the tank
- Whether the tank is thermally insulated, etc.

This guide directly addresses tank-type accelerated aging tests. Accelerated aging test parameters are presented which, if reported, will allow test data obtained by different laboratories at different times to be better compared.

This guide will:

- Identify the critical test parameters and techniques for their measurement and control.
- Review the levels of the test parameters, such as voltage (V), temperature (T), etc. It is not the intention of this guide to recommend specific test values.
- Identify the test parameters to be included in reports, etc.

The following will be discussed:

- Test specimens
- Prior tests and preconditioning of specimens
- Test structure
- Temperature
- Water
- Voltage
- Failures
- Abnormalities
- Diagnostics
- Data analysis
- Final report

It must be pointed out that some parameters are interrelated so that a change in one will have an effect on others (e.g., as already mentioned, the size of the tank could influence the temperature of the cable immersed in the water).

1.1 Scope

This guide provides information on the equipment, cable samples, test conditions, and measurements to perform accelerated aging tests on medium-voltage cables using water-filled tanks. The guide identifies the critical test parameters and describes techniques for their measurement and control. The implementation of the techniques will facilitate a comparison of data obtained by different laboratories.

2. References

This guide shall be used in conjunction with the following publications. When the following publications are superseded by an approved revision, the revision shall apply.

AEIC CS5-94, Specifications for Cross-Linked Polyethylene Insulated Shielded Power Cables Rated 5 through 46 kV.²

AEIC CS6-96, Specifications for Ethylene Propylene Rubber Insulated Shielded Power Cables Rated 5 through 69 kV.

3. Definitions, abbreviations, and acronyms

3.1 Definitions

3.1.1 abnormality: Any deviation from the pre-established test conditions, including the tolerance limits, that may affect the outcome of the test.

3.1.2 air failure: A failure in the cable above the waterline but below the termination.

3.1.3 termination failure: A failure in the portion of the cable, which does not have a metallic shield covering.

3.1.4 water failure: A failure in the active, shielded cable length that is below the waterline and which did not occur as a result of mechanical damage.

3.1.5 waterline failure: A failure at the interface between air and the tank water to include the distance of the total water line variation.

3.2 Abbreviations and acronyms

ACLT	accelerated cable life test
DSC	differential scanning calorimetry
EPR	ethylene propylene rubber
GMTF	geometric mean time to failure
I	conductor current
mle	maximum likelihood estimators
PL	polymer or polymer-lined
R	conductor resistance
SS	stainless steel
Tan δ	loss tangent of insulation
THD	total harmonic distortion
TRXLPE	tree retardant cross-linked polyethylene
V_o	line to ground voltage
ω	$2\pi f$ where f is the frequency in Hz of applied voltage
XLPE	cross-linked polyethylene

²AEIC publications are available from the Association of Edison Illuminating Companies, 600 N. 18th Street, P. O. Box 2641, Birmingham, AL 35291-0992, USA (<http://www.aeic.org/>). AEIC publications are also available from Global Engineering Documents, 15 Inverness Way East, Englewood, Colorado 80112-5704, USA (global.ihs.com/).

4. Test specimens

Table 1 lists a format for documenting the cable under test and provides example information. The values listed in Table 1 are compatible with tanks shown in Figure 1, Figure 2, and Figure 3.

Table 1—Example of cable documentation

Voltage class	15 kV, * 4.4 mm (175 mil) insulation thickness [†]
Conductor	53.5 mm ² (1/0 AWG) 1350 H-19 stranded compressed aluminum*
Conductor shield	0.38 mm (0.015 in) state grade and manufacturer, blend number, and date of manufacture
Insulation	4.4 mm (0.175 in) state grade and manufacturer, blend number, and date of manufacture
Insulation shield	0.76 mm (0.030 in) state grade and manufacturer, blend number, and date of manufacture
Metallic shield	≥6 #14 bare copper wires*
Jacket	None or identify material, thickness*
Cable extrusion	True triple
Cable extrusion date	To be included*
Cure process	Dry cure
Extrusion run identification	Job number, reel number
Cable manufacturer	To be included*
Cable quality control tests	To latest relevant AEIC spec*
Number of specimens in population	≥10*
Specimen total length	≥5 m (16 ft)
Specimen length under water	≥3.7 m (12 ft)
Number of cable coils	≥1
Inner diameter cable coil	610 mm (24 in)*
Date water added to tank	To be included
Date initial water added to conductor	To be included
Start voltage/heat cycles date	To be included
Replacement sample	Same type and construction of cable as test specimen if cable heating is necessary to maintain consistent water temperature*

*Values or tests in common use according to a survey conducted by the task force.

[†]Insulation thickness at point of failure is recommended for reporting in Clause 11, Clause 12, and Clause 13.

5. Prior tests and preconditioning of specimens

Partial discharge tests should be performed on every test cable to ensure that the cable and terminations are discharge-free prior to the aging test. The partial discharge test should be carried out according to AEIC CS5-94 and AEIC CS6-96.

It is well known that the most commonly used chemical cross-linking agent, dicumyl peroxide, produces a number of cross-linking agent by-products which include acetophenone, cumyl alcohol, α -methyl styrene and smaller quantities of other by-products. Their formation cannot be avoided, but they are migratory and can theoretically volatilize from the cable. Methods for by-product analysis and data for new and aged cables have been reported (Damon, et al., [B7], EPRI Report EL-7076 [B12]).

Silane-cured XLPE does not use dicumyl peroxide as the curing agent and thus contains different cross-linking by-products. No data are available at this time on the effects of the by-products for silane-cured insulation and the procedures in this clause may not be applicable to silane-cured XLPE. Also no data are available in the published literature on the effect of cross-linking by-products on EPR-insulated cables.

Residual cross-linking agent by-products may influence the electrical properties of polymeric insulating materials such as XLPE, tree retardant cross-linked polyethylene (TRXLPE), and EPR. The residuals will depend on the specific chemical reactions, which occur during manufacture and the rate at which the by-products subsequently diffuse through the extruded layers. Although the same cross-linking by-products occur in TRXLPE and EPR, the rate of diffusion will differ from that for XLPE and may vary for different TRXLPE and EPR formulations. In carefully controlled experiments on XLPE molded slabs and ribbons, removed from cables, the short-term 60 Hz breakdown strength increased but the impulse breakdown strength decreased with increased concentration of by-products (Damon, et al., [B7], Eichhorn [B9], EPRI Report TR-103908 [B13], Wartusch and Wagner [B30]). The ac breakdown strength of XLPE increased between 10% and 15% when the by-products were present up to 2% but decreased when the by-product concentrations exceeded 2% (EPRI Report TR-103908 [B13]). This study also showed that mixtures of the volatile by-products gave synergistic results. The electrical and water treeing resistance was improved by the presence of by-products (Ashcraft [B3], Wartusch and Wagner [B30]). Although this discussion is not intended to be a comprehensive literature review, the results show that the influence of the by-products on breakdown strength is quite complex.

There are limited data available on the effects of by-products on the long-term behavior of either molded slabs or cables. Controlled tests to examine the long-term effects are difficult to carry out due to the already-mentioned migratory nature of the by-products. An examination of new and service-aged steam-cured XLPE cables showed that the acetophenone level decreased from approximately 3000 ppm to 40 ppm during the first two years of installation and that very little (<15 ppm) remained after 8–10 years (Martin and Hartlein [B20]). The loss of by-products also occurred when a cable was stored on the reel. It was concluded that the loss of acetophenone would be expected to increase the water tree growth rate. In another study of steam-cured XLPE cables that had failed after 6–13 years in service at six utilities (EPRI Report EL-5387 [B10]) organic volatiles and halos were present in many of the cables. The total organic levels in the aged cables were <100 ppm. Although the levels of acetophenone were <10 ppm the levels of the cross-linking agent, dicumyl peroxide, were found to be variable, typically <20 ppm but up to 70 ppm in one cable after 11 years in service. The halo contained several thousand ppm of water. The ac breakdown strength was lower in the cables with halos.

The effects of three types of thermal preconditioning on dry-cured 15 kV XLPE cables aged in tanks have been studied (EPRI Report TR-108405-V2 [B14]). The preconditioning procedures were:

- a) Cyclically heat the conductor to 90 °C for 8 h on and 16 h off for 120 h.
- b) Heat the conductor to 60 °C continuously for 120 h.
- c) Heat the conductor continuously until the temperature of the insulation shield reaches 110 °C and immediately switch off the conductor heating current.

The results are shown in Table 2.

Table 2—Results of preconditioning tests on 15 kV XLPE cables aged in tanks

Type of preconditioning treatment	Age of cable after extrusion (months)	Geometric mean time to failure (GMTF) in days (-90, +90% Confidence Limits)	
		Aged at 4 V ₀ and 90 °C* (4/90)	Aged at 3 V ₀ and 75 °C* (3/75)
None (i.e., fresh cable)	2	64 (56, 74)	386 (366, 406)
90 °C on conductor cycled 8 h on 16 h off for 120 h	60	45 (40, 50)	264 (214, 325)
60 °C on conductor continuous for 120 h	60	46 (37, 57)	321 (309, 333)
Insulation shield to 110 °C then immediate cool down	54	103 (85, 124)	325 (284, 371)

*Maximum temperature during load cycling

Preconditioning treatment A subjected the cables to a total 40 h at 90 °C, 120 h at 60 °C for the cables in Treatment B, while the conductor temperature in Treatment C was not measured but was probably significantly greater than 110 °C for a short time (on the order of minutes). Neither the amounts of cross-linking by-products nor the morphology were measured before or after the preconditioning. Treatments A and B would be expected to yield different insulation morphologies. Melting and recrystallization will occur through part of the cable insulation wall thickness. Treatment C probably resulted in a temperature at the conductor in excess of 130 °C for a short time; this could lead to diffusion of species into or out of the shields into the insulation in addition to morphological changes, the rearrangement of crystalline imperfections, and relaxation of the insulation. Complete melting of the entire wall was probable as the temperature reached 110 °C; hence remelting and recrystallization of the entire wall occurred, in contrast to procedures A and B.

Preconditioning treatments A and B yielded similar values of GMTF for the 4/90 conditions. Although there was a 20% difference under 3/75 conditions there was considerable scatter in the data, particularly for treatment A. Without knowledge of the amounts of the cross-linking by-products or the morphologies it is difficult to interpret the results with respect to the effects of the cross-linking by-products or morphology. The results demonstrate that there is a wide variation in GMTF as the preconditioning procedure is changed for XLPE and therefore great care is required in applying a preconditioning procedure. Good temperature measurement and control are essential. The effect of such temperature variations on TRXLPE and EPR is not currently known.

Although their effects on the performance of extruded cable insulation are not precisely known, there is sufficient published data, at least for steam-cured XLPE, to show that an increased concentration of by-products improves the resistance of the insulation system to water treeing and that the concentration of by-products in XLPE gradually decreases with time. Based on the data in EPRI Report EL-5387 [B10] and Martin and Hartlein [B20], the concentration of cross-linking by-products in 15 kV XLPE cable may be less than 100 ppm after 10 years in service and, as a result, may not contribute to the tree retardancy. However, in accelerated aging tests lasting a year or even longer, if the accelerated temperature does not drive off the cross-linking by-products, an apparent improved resistance of the insulation to water treeing could result. Thus the long-term behavior, determined by the insulation with a low concentration of by-products, may not be as good as that predicted by the results of the accelerated aging test. To reduce this possibility the cables are preconditioned in order to reduce the amount of by-products in the insulation before being subjected to the aging test. The most common form of preconditioning is to subject the cables to elevated temperatures to increase the rate of diffusion of the by-products from the insulation (AEIC CS5-94, AEIC CS6-96).

In addition to removing the by-products, elevated-temperature preconditioning may:

- Cause chemical changes in the insulation depending on the temperature employed
- Cause morphological changes in the insulation due to partial melting and recrystallization (EPRI Report EL-5921 [B11])

These changes may also affect the water-treeing and long-term behavior and contribute to making preconditioning and its influence a very complex issue. Although the effects on XLPE are only partially understood, and the effects on TRXLPE and EPR are understood to a lesser extent, some form of preconditioning is preferred to reduce the level of by-products as long as the other changes mentioned here do not alter the mechanism of aging and loss of life. The preconditioning described here is based on limited measurements on 15 kV XLPE cables with no strand blocking (Abdolall [B1], EPRI Report EL-5387 [B10], Martin and Hartlein [B20]) and its aim is to reduce the level of the cross-linking by-products to less than 100 ppm. The choice of 100 ppm is based upon a limited number of measurements on cables that had been in service for up to 10 years and may have to be modified as more information becomes available. The procedure may not be suitable for silane-cured XLPE, TRXLPE, or EPR cables as no measurements have been made to determine the level of cross-linking by-products in service-aged cables with these insulations nor tests performed to determine the rates at which the by-products diffuse from these types of cables at elevated temperatures. In view of the unknowns, users should be cautious in interpreting the data.

The following are available procedures for preconditioning and analysis of cross-linking by-products:

- a) Heat the conductor by circulating current to $90\text{ }^{\circ}\text{C} \pm 2\text{ }^{\circ}\text{C}$ for a time to be determined such as 500 h in an open atmosphere. For steam-cured 15 kV cables, after 500 h at $90\text{ }^{\circ}\text{C}$ the amounts of acetophenone and α -methyl styrene were reduced to less than 10 ppm and cumyl alcohol to less than 100 ppm (Abdolall [B1]).
- b) Heat the conductor by circulating current to $90\text{ }^{\circ}\text{C} \pm 2\text{ }^{\circ}\text{C}$ for 72 h in an open atmosphere. However, significantly larger quantities of by-products may remain in the XLPE insulation after only 72 h.
- c) Analyze the by-products in the insulation and conductor shield before and after preconditioning and also after the aging. The residual volatiles are generally liberated from a sample and subsequently analyzed either using
 - 1) Solid head-space techniques, e.g., gas chromatography, or;
 - 2) A solution (e.g., liquid chromatography), or;
 - 3) Thermal desorption techniques.

Of items 1), 2) and 3) above, the most widely used is the solution technique wherein the by-products from a sample taken at 1/3 of the insulation thickness from the conductor are extracted using methylene chloride and analyzed using liquid chromatography. A more efficient procedure is to use the analytical techniques described in 4).

- 4) Analytical techniques, which rely on the direct introduction of volatile components into the chosen analytical equipment as they are extracted from the solid sample thereby keeping sample handling and errors to a minimum (EPRI Report EL-7076 [B12]). The same procedures have been used for TRXLPE and EPR but less information is available. However, the suggested protocols are not expected to introduce any concerns or uncertainties that have not already been expressed for XLPE insulation.
- d) Characterize the morphology or structure of the insulation before and after preconditioning and also after the aging. The morphology can be measured on samples from the inner 25% of the insulation wall thickness using differential scanning calorimetry (DSC). Prolonged exposure of XLPE to elevated temperatures below its melting point may introduce an additional peak(s) on the DSC thermogram. This additional peak(s) is related to the temperature to which the insulation specimen was subjected earlier and which signifies that polymer recrystallization has occurred (EPRI Report EL-7076 [B12]). This additional peak(s) in the DSC thermogram can be eliminated by heating the insu-

lation to a higher temperature or to its melting point (~ 106 °C) and then allowing it to cool. More sophisticated methods of measuring the morphology are available (EPRI Report EL-5921 [B11]).

- e) Measure the percent gel or extractables at the inner 25% of the insulation wall before and after preconditioning as defined in AEIC CS5-94 and AEIC CS6-96.

The purposes of the above analyses are to address one of the main concerns about the use of thermal preconditioning to remove the cross-linking by-products, i.e., the effects of the changes in insulation morphology that can occur during the preconditioning or cable aging that may influence the mechanism of aging. It should be noted that changes in morphology and the migration of cross-linking by-products will also occur during the aging in the tank and that these will depend upon the aging temperature. Thus, until more information becomes available, it is suggested that, for information purposes only, measurements be made of the cross-linking by-products and also the morphology of the insulation before and after the preconditioning, and also after the aging.

Any interpretation of cable test data will be incomplete without the actual details of the location of the sampling for the cross-linking by-products with reference to the test cable and of the analytical methods used to measure the by-products. It is therefore suggested to report these two parameters while giving quantitative information on the concentration of by-products so as to track down the effect of these on cable aging precisely.

Monitoring of the amounts of by-products in cables before the aging tests may lead to a refinement of the preconditioning procedure later. For example, levels of one or more by-products could be specified or the conditions for preconditioning changed in future editions of this guide.

6. Test structure

It should be recognized that tank shape, size, material of construction, water volume and characteristics, and number of cables in the tank will have a direct influence on important parameters, the cable and water temperatures, and ultimately on the results of the test. It is not practical to list all of the combinations of these parameters in this guide. It is, however, possible to list general guidelines, suggest reported data that will facilitate the comparison of data generated by different test methods, and provide typical values for those parameters considered critical.

Figure 1, Figure 2, and Figure 3 show several tank layout schematics. They are provided as a reference for the following paragraphs on tank structure and as a guide for standardization in the development of new testing facilities. They are not intended to preclude the use of other arrangements. It should be noted that not all elements shown in the schematics will necessarily be used for all test setups. In Table 3 and Table 4, capitalized letters in parentheses refer to elements in the schematics.

The tank structure is as follows:

- Tank shape. The typical reservoir shape is rectangular, but others such as cylindrical, as shown in Figure 3, are in use. Tank shape should be reported.
- Tank size. The tank used should be large enough to accommodate at least ten cable specimens or a single cable equivalent in length to 10 specimens plus any control samples such as a “dummy loop” used in induced current heating/temperature monitoring. There should be sufficient distance between cable specimens and tank sides, bottom, and other cable specimens to prevent uneven heating of any individual specimens and to allow adequate circulation of the water.

When data from various tests are compared, the number of cable specimens plus the following tank size variables should be considered: length, width, height (in the case of generally rectangular shapes, or the appropriate dimensions for other shapes), and depth of water. Where necessary because of unusual shape or design, the ratio of water volume to submerged cable volume should

also be considered. These parameters will have significant effects on the temperature of the water if the water temperature is not controlled. However, if the water temperature is controlled, less attention to tank dimensions and structure given in Table 2, Table 3, and Table 4 can be tolerated.

Table 3 lists nominal size and shape parameters currently in use in North America.

Table 4 lists the commonly used dimensions of tanks and materials to be used according to their shapes (Figure 1, Figure 2, and Figure 3).

- Materials of construction. In general, the inner tank surface, the specimen mounts, and any other materials making contact with the water in the tanks should be constructed from suitable inert materials that will not corrode in the presence of water and will not form an electrolytic cell with any component in the cable sample. SS tanks are usually grounded. In particular, the tank should not cause the introduction of a significant level of ion contamination, which may lead to erroneous results.

The type of material contacting the water should be reported. Also, any materials used to insulate the tanks or used to insulate or retard surface evaporation of the water, and their thicknesses should be reported to allow determination of their impact on water temperature and quality.

Typical materials of construction in current use are shown in Table 5.

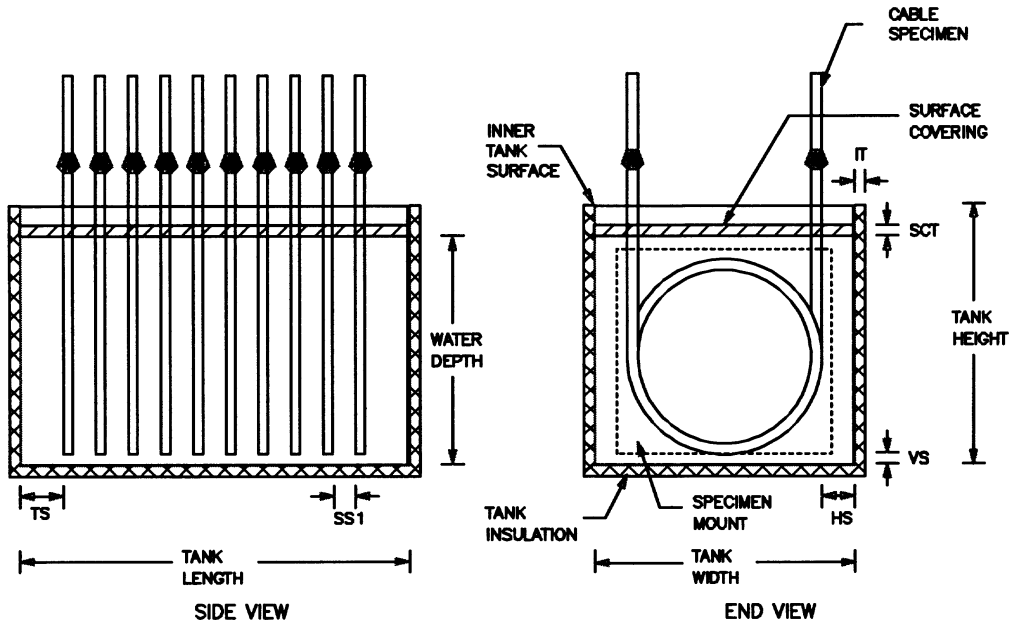

Figure 1—Layout tank type #1

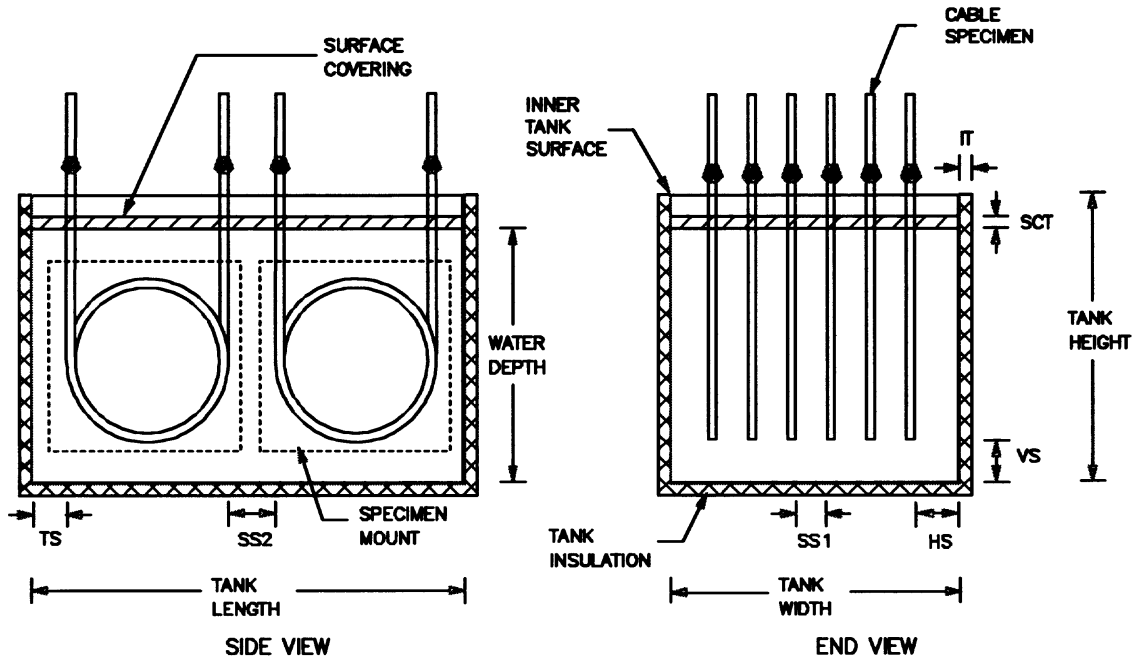

Figure 2—Layout tank type #2

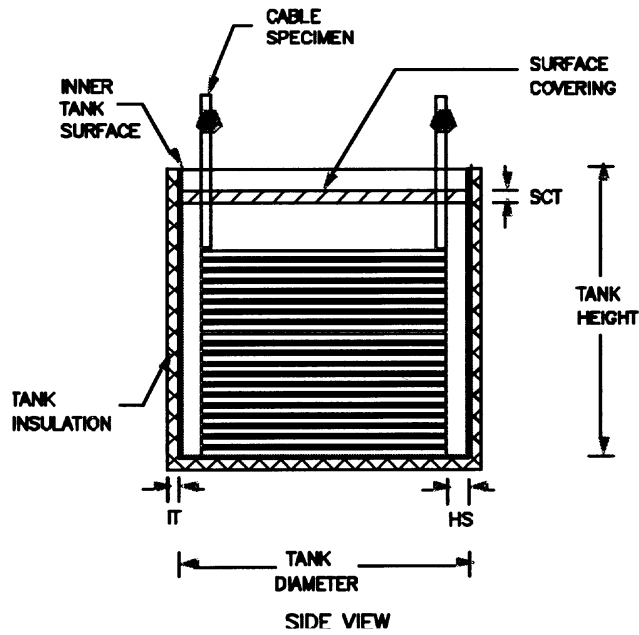

Figure 3—Layout tank type #3

Table 3—Nominal tank sizes

Typical tank shapes and sizes										
Layout tank type	1	1	1	2	2	2	2	2	1	3
Tank dimensions, mm (in)										
Length	1500 (60)	1650 (65)	3000 (120)	1500 (60)	1550 (61)	1650 (65)	2100 (84)	2100 (84)	3250 (125)	1220* (48)
Width	1220 (48)	1350 (53)	1220 (48)	1220 (48)	890 (36)	1120 (44)	1070 (42)	1220 (48)	1220 (48)	1220* (48)
Height	1050 (42)	1500 (60)	1220 (48)	980 (39)	910 (36)	980 (39)	1220 (48)	1220 (48)	1220 (48)	1220 (48)
Sample to tank spacing, mm (in)										
Side (HS) [†]	300 (12)	25 (1)	230 (9)	75 (3)	50 (2)	65 (2.5)	75 (3)	25 (1)	305 (12)	40 (1.5)
End (TS) [†]	125 (5)	75 (3)	220,430 [‡] (8.5, 17) [‡]	38 (1.5)	65 (2.5)	50 (2)	75 (3)	130 (5)	100 (3.9)	—
Bottom (VS) [†]	150 (6)	130 (5)	50 (2)	230 (9)	140 (5.5)	130 (5)	75 (3)	25 (1)	305 (12)	0 (0)
Sample to sample spacing, mm (in)										
(SS1) [†]	130 (5)	59 (2.5)	220 (8.5)	115 (4.5)	115 (4.5)	140 (5.5)	140 (5.5)	130 (5)	145 (5.7)	0
(SS2) [†]	—	—	—	340 (13.5)	340 (13.5)	420 (16)	420 (16)	380 (15)	—	—
Water depth, mm	900 (36)	1170 (46)	1170 (46)	915 (36)	810 (32)	915 (36)	1140 (45)	915 (36)	1120 (44)	1220 (48)

*Tank shape reported as cylindrical, length, and width = diameter.

[†]Refer to spacings in Figure 1, Figure 2, and Figure 3.

[‡]Tank to sample spacing reported as different for each end.

Table 4—Commonly used materials and tank dimensions

Tank details	Type 1	Type 2	Type 3
Length, mm (in)	≥1140 (≥ 45)	≥1500 (≥60)	≥840 (≥33)
Width, mm (in)	≥800 (≥30)	≥800 (≥30)	—
Height, mm (in)	≥910 (≥36)	≥910 (≥36)	≥910 (≥36)
Side spacing (HS) [*] , mm (in)	≥50 (≥2)	≥50 (≥2)	≥50 (≥2)
End spacing (TS) [*] , mm (in)	≥75 (≥3)	≥50 (≥2)	—
Bottom spacing (VS) [*] , mm (in)	≥50 (≥2)	≥50 (≥2)	≥0
Sample spacing 1, mm (in)	≥50 (≥2)	≥50 (≥2)	≥0
Sample spacing 2, mm (in)	—	≥75 (≥3)	—
Water depth, mm (in)	≥800 (≥30)	≥800 (≥30)	≥800 (≥30)
Tank material, mm (in)	SS [†] or PL [‡]	SS or PL	SS or PL
Tank insulation, mm (in)	Water resistant	Water resistant	Water resistant
Insulation thickness (IT) [*] , mm (in)	≥25 (≥1.0)	≥25 (≥1.0)	≥25 (≥1.0)
Specimen mount, mm (in)	Polymeric	Polymeric	Polymeric
Surface cover, mm (in)	Polymeric	Polymeric	Polymeric

^{*}Refer to Figure 1, Figure 2, and Figure 3.

[†]Stainless steel

[‡]Polymer-lined

7. Temperature

Temperature has been shown in previous studies to play a very significant role as an aging parameter for some cables in tank-type testing (Lyle [B19]). In order to elevate the conductor temperature to the levels required for accelerated aging of the cable, current is usually induced into the conductor using a current transformer. Cable heating occurs due to resistive losses in the conductor. This method of heating is the common practice and preferred method since cables are heated in this way in actual field use.

Conductor heating may be cyclic or continuous. The usual practice is cyclic heating because this type of heating more closely simulates the type of heating that a cable would experience in actual service. Current heating cycles on a daily 8 h on, 16 h off, seven days a week, is the most common practice. It should be noted that tests without conductor heating are also performed.

7.1 Test sample conductor temperature

Since part of each test sample length is in water and part is in air, the thermodynamics of heating and cooling the test samples can be quite complex. For this reason, it is important that the conductor temperature be monitored in both the water and air portions of the test sample, preferably at the hottest spot in both places. Locating these hot spots, should they exist, may take some experimentation. During ACLT, temperature

Table 5—Commonly used construction materials for tanks

	Inner tank surface		Tank insulation		Specimen mounts	Surface cover
	Material	Thickness, mm (in)	Material	Thickness, mm (in)		
1	SS*	2.2 (0.087)	Foam	25 (1.0)	Acrylic sheets	PL [†] spheres
2	SS	0.8 (0.03)	Fiberglass	75 (3.0)	PVC pipe racks	Plexiglass
3	Vinyl liner		Concrete structure with sand on bottom and foam on sides	150 (6) concrete sides and bottom 150 (6) sand bottom only	Fiberglass racks	Styrofoam
4	SS	3.2 (0.125)	Redwood	41 (1.63)	Acrylic sheets	PL spheres
5	SS	3.2 (0.125)	Redwood	41 (1.63)	Acrylic sheets	PL spheres
6	SS	1.6 (0.06)	Redwood	41 (1.63)	Acrylic sheets	PL spheres
7	SS	1.6 (0.06)	Redwood	41 (1.63)	Acrylic sheets	PL spheres
8	SS	5 (0.19)	Foam	51 (2.0)	Polypropylene	Polycarbonate
9	Polyethylene	8 (0.32)	Fiberglass	38 (1.5)	None	
10	Polyethylene		Fiberglass		None	
11	Galvanized steel with vinyl liner	1 (0.04)	Foam	38 (1.5)	Fiberglass racks	

*Stainless steel

†Polymer

monitoring is typically accomplished by placing thermocouples on the conductor of a dummy cable. The concentric neutral of the dummy cable should only be grounded at one end to avoid circulating currents. A dummy cable experiences approximately the same heating conditions as the active cables but has no voltage on the conductor except the voltage necessary to drive current in the conductor. This condition is complicated if the insulation material of the active samples has high dielectric losses and experiences heating due to the application of voltage. To accurately determine what the actual temperature differences are between the dummy cable and the active cables, a temperature profile must be established (see 7.4). Figure 4 shows a typical dummy sample with thermocouples located on the conductor in the air portion of the sample, on the conductor at the mid-point of the water section, and on the cable surface in the water.

Figure 5, Figure 6, and Figure 7 show progressively more complex heating control schematics using a dummy cable. These heating control schematics are only examples. Other control schemes may be acceptable as long as they provide for reproducible heating of the test samples.

Maximum conductor temperatures of ambient to 90 °C have been used in tank tests. In some cases, this conductor temperature is measured on the section of the cable sample in air, and in other cases, it is measured on the section of cable sample in water. The conductor temperature of the active test sample in water is the critical temperature; the conductor temperature of the active test sample in air is of secondary importance. However, care should be taken to prevent overheating in this portion of the test sample. With water in the conductor, no portion of the active test sample conductor should exceed 100 °C.

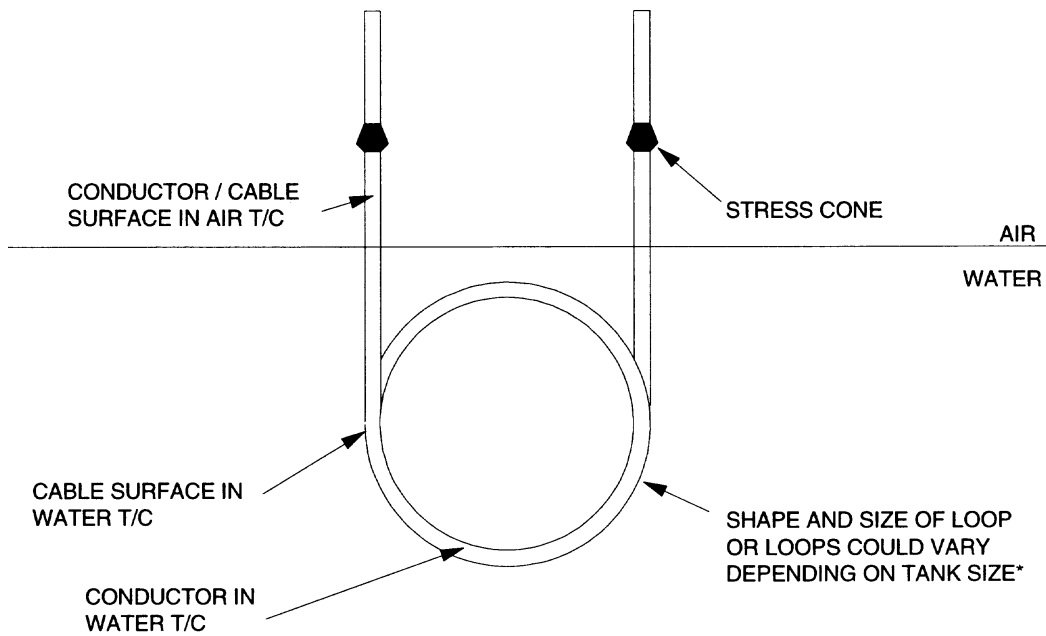

T/C Thermocouple
*Not less than minimum radius

Figure 4—Dummy used for temperature measurements

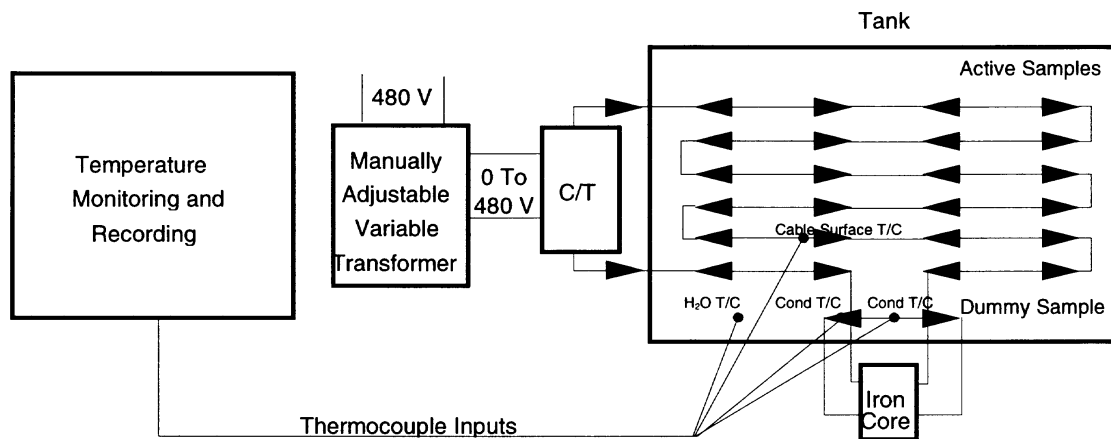

T/C Thermocouple
C/T Current transformer

Figure 5—Typical heating control schematic using manually adjustable variable transformer

The time-temperature profile of the active test sample in water is a critical parameter in ACLTs. Examples of some time-temperature profiles are shown in Figure 8 and Figure 9. It is not the purpose of this guide to recommend a particular profile. The conductor temperature profiles, which are used in ACLTs, should not be strictly defined as there is still much to learn in developing a reliable ACLT. Different types of cable insulations behave differently in the ACLT for the same test conditions. Typically used test temperatures are listed in Table 6 in Clause 10.

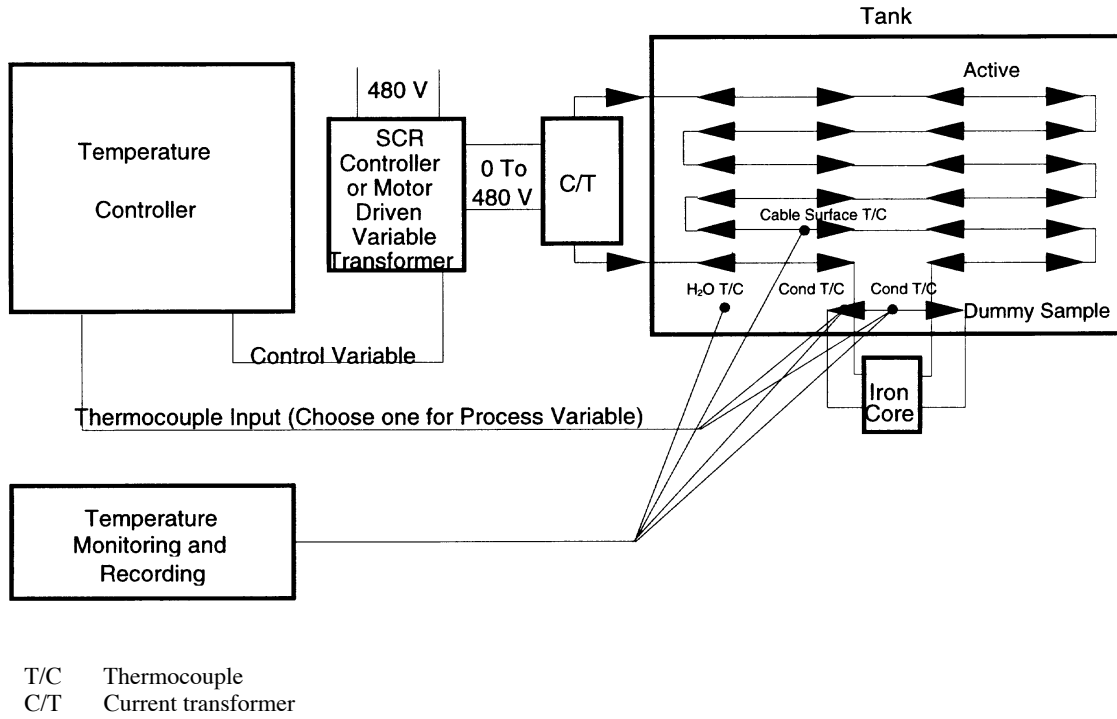

Figure 6—Typical heating control schematic using a temperature controller

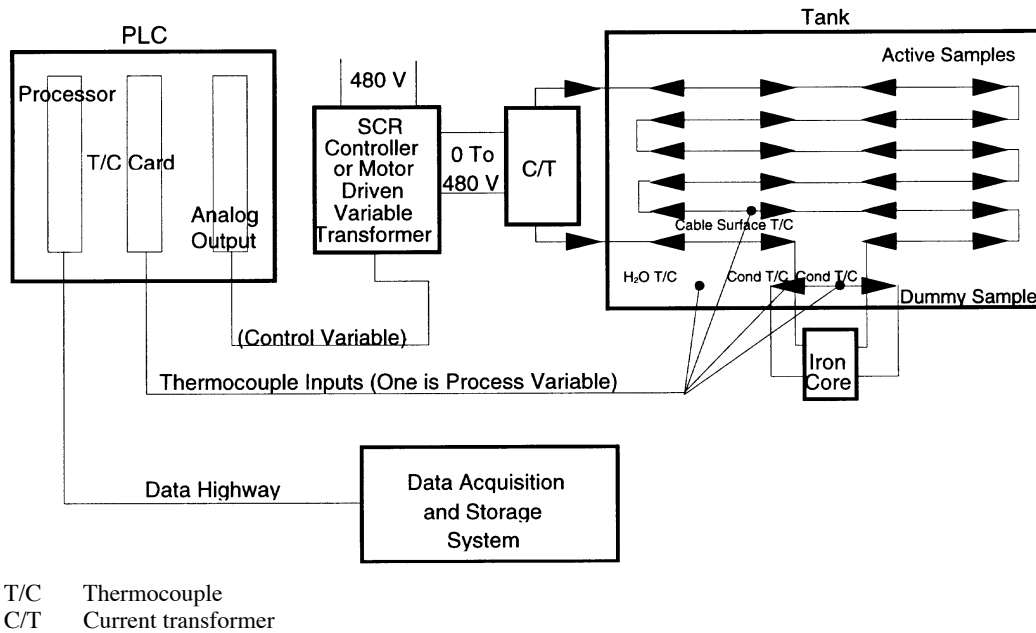

Figure 7—Typical heating control schematic using a programmable logic controller

90°C CONDUCTOR IN AIR - 2 AWG-AL - 0.175 EPR
WATER TEMP. NOT CONTROLLED

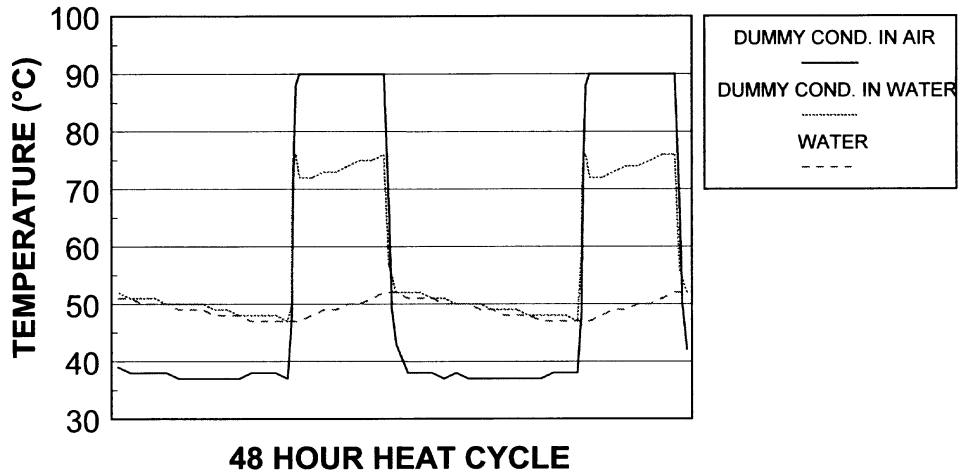

Figure 8—Time temperature profile

75°C CONDUCTOR IN WATER - 2 AWG - 0.175
WATER TEMP. CONTROLLED

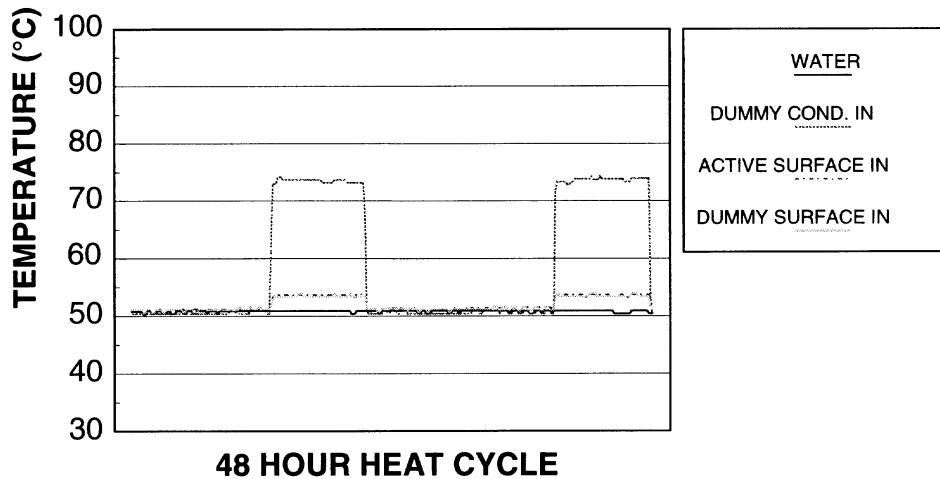

Figure 9—Time temperature profile

7.2 Water temperature

Throughout the tank, the water temperature should be uniform at any given time. This is most often achieved by circulating the water in the tank and making provisions for evenly distributing the circulated water. If some form of water circulation is provided and adequate precautions have been taken to insure a uniform distribution of the circulated water, only one temperature probe in the water tank should be necessary. Hollow plastic spheres or styrofoam sheets are often used on the water surface to insulate it from the surrounding air and to minimize water evaporation.

Water temperature may or may not be controlled. In order to maintain a consistent water temperature profile, cooling or heating may be required during the test cycle. Where water temperature is not controlled, the water temperature simply rises and falls with the conductor heat cycles. In this case the water temperature will depend on tank size, shape, water volume, number of cable samples, etc.

7.3 Ambient temperature in the test area

Ambient temperature in the test area should be monitored and recorded. If the tank water temperature is not controlled, it is desirable to control this variable as a means of achieving a more repeatable time-temperature profile.

7.4 Establishing a temperature profile

On cable constructions, which use insulation materials with low dielectric losses, it is possible to establish accurate temperature profiles by setting up a tank with cables of the same construction (not the actual ACLT samples) and applying heating load cycles without the application of high voltage. This allows thermocouples to be placed on the conductors of the active samples, which would normally be energized during the ACLT. It is important that temperature profiles be established at the following locations:

- a) The active test cables
 - 1) Conductor temperature in water *and* air
 - 2) Cable surface temperature in water *and/or* air
- b) A dummy cable, if used for temperature monitoring and control
 - 1) Conductor temperature in water *and* air
 - 2) Cable surface temperature in water *and/or* air
- c) Water temperature
- d) Ambient temperature

The temperature of the conductor will vary between the water level and the stress cone and could be higher under the stress cone. Dummy cables used for temperature monitoring and control may not experience the same heating currents as active test cables due to losses in the iron core used to isolate the dummy cable from the high-voltage source. These losses can result in slightly different conductor temperatures on the dummy cable and the active test cables. These temperature differences are believed to be very small and can be determined while establishing the temperature profiles.

Conductor heating currents in both the active test cables and the dummy test cable (if used) should be measured and recorded while establishing the temperature profiles since these currents have a direct relationship to conductor temperatures. These currents should be periodically compared to the conductor heating currents measured during ACLT as a means of verifying that no significant changes have occurred since the temperature profiles were established. All conductor heating currents should be measured with a true RMS meter.

For cables exhibiting high dielectric loss ($V^2\omega C \tan \delta$) characteristics (measured and calculated under test conditions), the energized cables will run hotter than an unenergized dummy cable in the same tank. Dielectric heating may also occur in tests conducted at ambient temperature. For these cases, an additional correction factor or adjustment is required to ensure the energized cable is at the specified test temperature. One simple and practical method to achieve temperature control is to lower conductor loss (I^2R) by an amount equal to the dielectric loss calculated from the actual measured cable characteristics. If dielectric heating is significant during tests at ambient temperature, cooling of the water may be necessary.

7.5 Monitoring/controlling temperatures during the ACLT

Once the temperature profiles have been established and the actual ACLT cable samples have been placed into the tank and energized with the application of high voltage, it is important that the following locations be monitored and/or controlled:

- a) The active test cables
 - 1) Cable surface temperature in water and/or air
- b) A dummy cable if used for temperature monitoring and control
 - 1) Conductor temperature in water and/or air
 - 2) Cable surface temperature in water and/or air
- c) Water temperature
- d) Ambient temperature

It is intended that there should be excellent correlation between the values measured during the ACLT testing and those values obtained from the temperature profile measurements.

7.6 Temperature measurement techniques

Accurate measurements of conductor temperature or cable surface temperatures with thermocouples require that proper techniques for preparation and mounting of the thermocouples be used. The techniques given in 7.6.1 and 7.6.2 for preparation and mounting of thermocouples are a compilation of those used at several laboratories throughout North America.

7.6.1 Conductor temperature measurements using thermocouples

- a) **Lab A.** To measure the temperature of the conductor of the dummy sample, commercially available SS-sheathed, Type T or Type K thermocouples are used. The sheaths have a 0.5 mm (20 mil) outside diameter and are electrically isolated from the thermocouple junction located at the end of the SS sheath (ungrounded).

To attach the thermocouple to the conductor, a hole is drilled perpendicular to the cable axis down to the conductor. A sample piece of cable is often used to gauge the correct drilling depth. The drill bit diameter is approximately 0.53 mm (21 mil). The end of the thermocouple sheath is coated with a high temperature heat sink compound, which is commonly used as a heat sink compound for solid state electronics.

The thermocouple sheath is then placed into the hole down to the conductor. A small bend is put in the sheath such that the sheath rises about 2.5 mm (0.10 in) above the cable surface at the drilled hole. It immediately bends back down to the cable surface. Silicone tape is wrapped around the cable over this bend, placing a constant inward force on the sheath, keeping it in good contact with the conductor. The silicone tape should be applied so that the thermocouple is held securely in place but not so tight that the cable deforms during load cycling.

- b) **Lab B.** Cost effective unsheathed thermocouples can be fabricated from Type J (note that unsheathed Type J may corrode in water) or Type T thermocouple wire. Thermocouple wires with 20–24 AWG solid conductors seem to be well-suited for the fabrication of thermocouple junctions, which can be used to measure conductor temperature. The tips of the thermocouple wires are usually joined together by a specially built thermocouple welder that utilizes a capacitive-discharge technique. To locate the thermocouple junction next to the cable conductor, a 6.3 mm (0.25 in) diameter plug of insulation shield + insulation + conductor shield material is removed using a sharp coring tool. The thermocouple wires are bent at a 90° angle near the junction so that the junction can be placed flat against the conductor surface which was exposed by removing the plug. The same plug of insulation shield + insulation + conductor shield material is then replaced and held in place by wrap-

ping self-amalgamating tape around the power cable. A multi-purpose room-temperature vulcanized (RTV) sealant may also be used to seal any gaps around the top of the plug prior to the application of the tape. To insure that the thermocouple junction is making contact with the conductor, an ohmmeter is used to check continuity between each thermocouple wire and the cable conductor.

Several thermocouples are mounted on the conductor surface in close proximity to the measurement area as a means of determining when a particular thermocouple is no longer functional. It is also important to remember that the conductor temperature will not always be the same along its length. To establish accurate temperature profiles, several thermocouples should be installed along the length of the conductor.

- c) **Lab C.** Prepare the thermocouple junctions by welding the tips of the thermocouple wire (usually Type J). Smaller thermocouple wires at the point of temperature measurement will disturb the measurement area the least. Being careful not to drill into the conductor, drill four small holes into the insulation separated by 90° along the circumference of the cable. The thermocouple junctions are placed into these small holes. The thermocouple junctions should be firmly seated against the conductor. On stranded conductors, two adjacent outer wires can be slightly separated so that the thermocouple junction can be placed between the wires. Once the thermocouples are in place, machined plugs of polyethylene with the same diameter as the drilled holes are placed over the thermocouples, and the plugs are then secured by taping them in place. Another set of thermocouples located 60–90 cm (2–3 ft) away, and mounted in the same manner as the first set, should also be monitored to insure the integrity of the temperature measurements.

7.6.2 Outside cable surface temperature measurements using thermocouples

- a) **Lab A.** To measure the temperature of the insulation shield or jacket, a welded bead is made on a Type T or a Type K thermocouple. The bead is then soldered to a small square of copper tape. The copper tape is typically 13 mm × 13 mm × 0.13 mm (0.5 in × 0.5 in × 0.005 in) thick. Heat sink compound is applied to the side of the copper tape opposite the thermocouple and placed against the insulation shield or the jacket. It is then held in place with silicone tape. The silicone tape should be applied so that the thermocouple is held securely in place but not so tight that the cable deforms during load cycling.
- b) **Lab B.** To measure the temperature of the insulation shield or jacket, commercially available SS-sheathed Type T or Type J thermocouples are used. The sheaths are electrically isolated from the thermocouple junction located at the end of the SS sheath (ungrounded). These SS-sheathed thermocouples are secured to the insulation shield or jacket with self-amalgamating tape.
- c) **Lab C.** To measure the temperature of the insulation shield, a welded bead is made on a Type T or a Type J thermocouple. The bead is then soldered to the center of 25 mm × 25 mm (1.0 in × 1.0 in) square of copper tape. The copper square is then laid flat on the insulation shield and secured with tape. To measure the insulation shield surface temperature on a jacketed cable, a window is first cut in the jacket by folding back a small flap of the jacket material. The copper tape square with the thermocouple is then laid flat on the insulation shield surface and the flap of jacket material is replaced and secured with tape.

Several of these thermocouples are usually secured around the circumference of the cable in at least three different locations along the length of the cable.

8. Water

Water is one of the primary test parameters in tank-type testing. Since moisture in the insulation and its ability to transport ions may be linked to cable aging through water tree formation (Pélissou [B23], UNIPEDA-DISCAB [B28]) careful control and monitoring of the water quality are essential for test repeatability. Having the same water characteristics before aging and monitoring and changing the water when the prescribed resistivity limits are exceeded are necessary to ensure future comparisons between laboratories. This clause provides information on how to maintain uniform water quality.

In tank-type aging tests, water is used to fill the tank and the interstitial spaces of the sample inner conductor and, also, to make up evaporative losses from both the tank and the conductor. It is preferred that the water for the tank be initially deionized (charcoal prefilter, using cation and anion resin beds) with a resistivity not less than 1000 $\Omega\cdot\text{m}$. Since the water quality can be affected by electrical breakdown, insertion of new cable samples and the mixing of different cable types, the water in the tanks should be changed totally or partially when the resistivity is less than 250 $\Omega\cdot\text{m}$. Based on the data shown in Figure 10 for six tanks over a period of more than 36 months (EPRI Report TR-108405-V2 [B14]) it is recommended that the water be checked by monitoring the pH and resistivity monthly. Ion nature and concentration may play a role in the life of cables in the ACLT (EPRI Report TR-108405-V2 [B14]). These records will allow variations within a tank and between tanks to be tracked as a function of time, and ultimately could help to explain particular sample failures. Furthermore, an adequate water/cable volume ratio should be fixed and maintained during the aging period, as it influences the impurity concentration, hence the frequency of water changes, and, also, the time/conductor temperature characteristics. Two ratios have already been suggested (120/1 in Katz, et al., [B16] and 47/1 in Walton, et al., [B29]) and at least 40/1 is recommended. To keep the water volume constant, refilling can be performed automatically by means of a floating valve to a control level of ± 13 mm (0.5 in), using deionized water similar to that initially used. The water should be circulated continuously to avoid hot spots, within a temperature variation of $\pm 2^\circ\text{C}$, to ensure uniform aging.

Similar recommendations apply to the water in the cable strands. For the sake of uniformity and for practical reasons, it is usually similar to the surrounding water (charcoal prefilter, using cation and anion resin beds) with a resistivity not less than 1000 $\Omega\cdot\text{m}$. To make sure all interstices are filled, a water pressure of 70–200 kPa (10–30 psi) should be applied at one end of each cable specimen. Pressurization should only be used when the cable is at room temperature. Since water corrodes the strands over time, particularly those made from aluminum (Luzzi [B18]), they should be checked for blockage when the cable is at room temperature using deionized water at a sufficient pressure. Pressures up to 200 kPa (30 psi) may be used. If no water flow is observed within 5 min the corrective actions listed in Clause 12 should be investigated. If frequent blockages are occurring, more regular checks should be considered.

It is cautioned that if tap water or controlled ion salt water (e.g., 0.1 Normal NaCl) is used initially, the ACLT results may change; different aqueous solutions may yield different ACLT results, even though all other conditions are equal. This is because different ions penetrate into the insulation wall at different rates and may induce different aging results.

9. Voltage

Voltage stress is a critical parameter for the aging process and is required, along with water, for water tree growth. Its level, stability, and quality are all important parameters that must be regulated and recorded. It should be noted that water tree initiation and growth are a function of localized electric stresses that cannot be directly measured.

The voltage is applied between the cable conductor and the metal shield or neutral wires. One end of the neutral of each cable is connected, either directly or through a fuse, to the high-voltage circuit ground. The voltage level should be controlled to within at least $\pm 5\%$ and be free from substantial harmonic content. Harmonic content of the test voltage can be specified by total harmonic distortion (THD), but the overall effects of harmonics on the aging of the samples has not been investigated. The average voltage stress level chosen is left to the individual, but is usually between 2 kV/mm and 8 kV/mm. The relationship to rated line to ground voltage may be preferred, between $2 V_0$ and $4 V_0$. It must be noted that while aging may be accelerated using above normal voltage stresses, too high a stress might introduce a mechanism of aging that would not occur at normal stress. It is important that the voltage measuring equipment be calibrated regularly, preferably at least once a year. Also the voltage should be continuously monitored regularly for several days to ensure the voltage variation is within $\pm 5\%$. The monitoring should include weekdays and a weekend. As an example, if the aging is assumed to follow an inverse power law model ($V^n t = \text{constant}$) with an exponent n of 4, a voltage variation or error in calibration of $\pm 5\%$ will result in a time variation of $\pm 20\%$. Typically used test temperatures and voltages are shown in Table 6 in Clause 10.

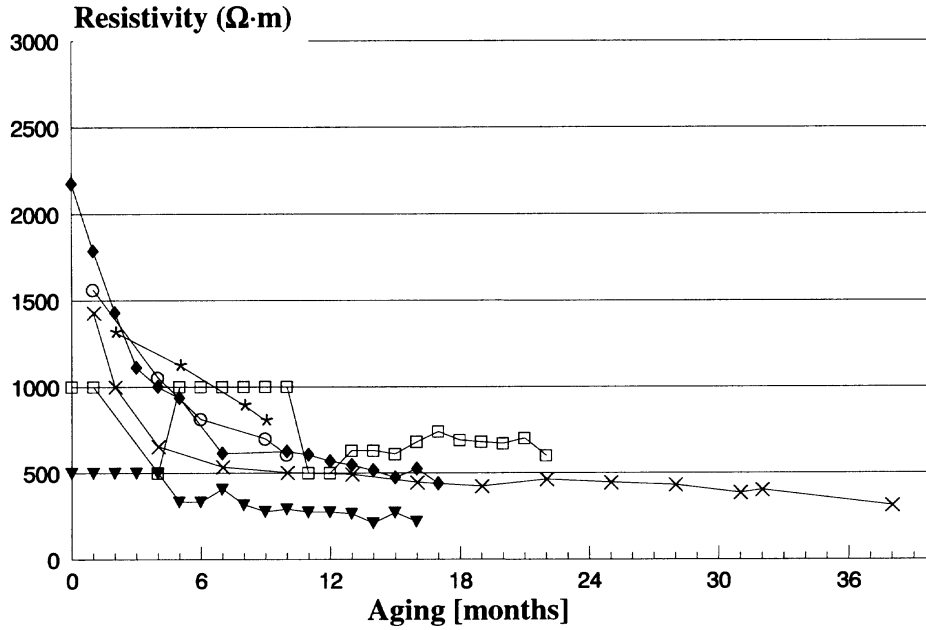

(a)

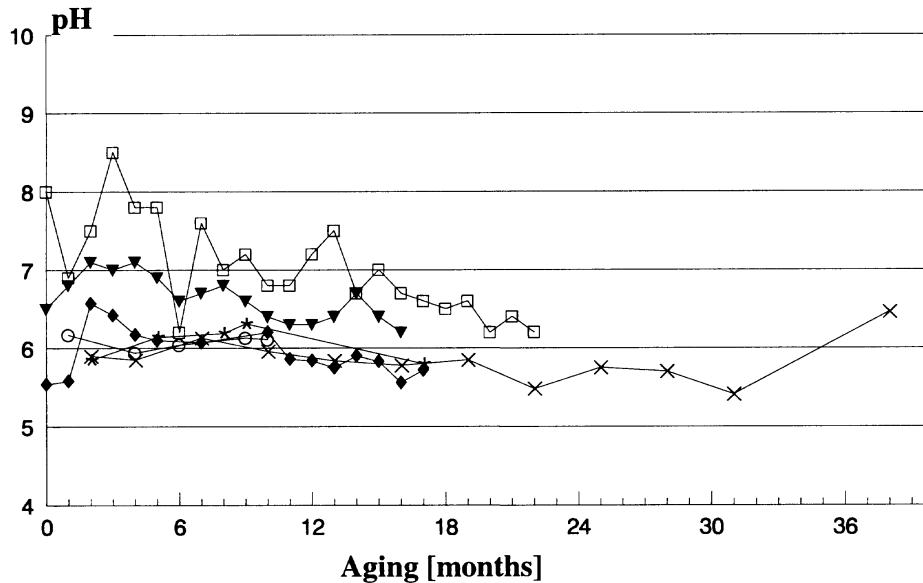

□ Tank 10 ▼ Tank 19 * Tank 29 ○ Tank 39 × Tank 52 ◆ Tank 56

(b)

Figure 10—Tank water resistivity and pH for six tanks as a function of time (EPRI Report TR-108405-V2 [B14])

Interruptions to the test voltage are needed for the maintenance of water levels, etc., and forced when samples fail. The duration of an interruption must be minimized by having replacement samples available and methods to detect a failed cable in place before startup. The time and duration of the interruptions should be recorded. Damage to the sample during failure can be limited by providing a high source impedance power supply, or alternatively, an overcurrent trip device in the circuit. For example, the neutral of each test cable may be connected to the high-voltage circuit ground through a fuse (~2 A) to facilitate identification of a failed cable.

Voltage frequency is usually specified as either 50 Hz or 60 Hz. Extensive tests have been done up to 8 kHz, but frequencies higher than 50 Hz or 60 Hz require expensive power supplies that must be protected against surges when samples fail as the output stages of the power supplies are vulnerable to damage. For these reasons, no tank tests are currently performed at high frequency in North America. Different results may occur when different frequencies are used.

In some test procedures, voltage surges are introduced intentionally during an aging program to include the effects of lightning impulses and switching surges that occur during the service life of an underground cable (Hartlein, et al., [B15], Katz, et al., [B16]). Surges can occur unintentionally when cable samples fail. If the aging test area is located near a potential site of surges, the test setup should be checked for voltage transients. The magnitude, wave shape, and frequency of intentionally applied impulses or surges should be accurately recorded.

It should be noted that dc voltage has also been applied during aging studies, and has been shown to influence cable life (Srinivas, et al., [B25]). If dc voltage is used in the test procedure, the test method should be noted, e.g., voltage level, time of application, and time of grounding. DC testing is not recommended in ACLT tests.

Termination of the cable samples should receive special consideration as normal stress cones will be overstressed during the aging and could lead to premature failure. An over-designed cable termination system should be considered to provide adequate stress relief at the expected high voltage level for the duration of the test program. Premature stress cone failures are expensive and time consuming.

Diagnostic tests (see Clause 13) using high voltages may be carried out both before and after the aging test. These tests should be performed as soon as possible after the sample is removed from the aging test program as voltage relaxation can change the result obtained. The samples should be stored in water to reduce drying. Test voltage measurements should be made on the high voltage side with a suitable divider, continuously monitored and displayed.

10. Test matrix

As mentioned earlier, two of the most significant cable aging parameters are conductor temperature in the water and voltage stress. Because of the complex nature of accelerated aging tests on extruded dielectric cables, this guide does not specify these or any other test parameters. However, in an effort to allow a comparison of test results developed at two different laboratories, a matrix of commonly used test voltages and conductor temperatures in the water is provided in Table 6. The values were selected to cover test parameters typically used by cable researchers. They are also broad enough to allow for a wide variety of aging conditions. It is not intended that a cable be evaluated by subjecting lengths to all test conditions but that laboratories select one (or more) set(s) contained in the table. In time, a specific set of test conditions may evolve that could then be acceptable as a standard. This set of conditions might be different for each particular insulation system, e.g., the accelerated test conditions for XLPE may not be the same as those for TRXLPE or EPR.

Table 6—Designation of common conductor temperatures in the water and voltage test conditions

Test voltage	Designation of test conditions			
	30 °C or ambient	45 °C*	60 °C*	90 °C*
1 x V ₀ [†]	1/30	1/45	1/60	1/90
2 x V ₀	2/30	2/45	2/60	2/90
3 x V ₀	3/30	3/45	3/60	3/90
4 x V ₀	4/30	4-45	4/60	4/90

* Conductor temperatures in air may be higher.

[†] Line to ground voltage (8.7 kV for 15 kV cables).

The voltages are applied between the conductors and the neutrals of the cables. The temperature is generally the maximum conductor temperature achieved during the eight hour “current-on” period when load cycling is used. To reliably compare test results from different laboratories, the two laboratories should use the same test protocol. This includes not only the same test voltage and the maximum test temperature, but also the same temperature profile during a load cycle if load cycling is used. That is, the curve of time versus temperature should be the same for both laboratories. The temperature gradient across the insulation should also be the same for both laboratories. A reliable comparison of test results is only possible if both laboratories subject test samples to the same test parameters.

11. Failure

The following information is considered critical for a thorough understanding of the test evaluation. Also, a list of codes is provided to facilitate reporting the data. It is important that the locations of the failures be reported since the cables may have seen different temperatures at different locations in the tank. The method of locating the failure should also be reported.

Failure code	Type
A	In air
T	Termination
WL	At waterline
W	In water
D	Removed for diagnostics
C	Censored from data analysis, but should be reported and used in conjunction with one of the above
M	Mechanical damage

For abnormality codes, see Clause 12.

Measurements

t	Insulation wall thickness at failure
R_1	Radius under insulation
R_2	Radius over insulation

Suggested information to report on each sample in test evaluation

- Position in tank
- Time under voltage
- Number of current cycles
- Test days, i.e., time in water
- Type failure
- Abnormalities
- Measurements (t, R_1 , R_2 , L)

12. Abnormalities

Although this type of testing is intended to accelerate cable aging, a single evaluation can go on for months and even years before it is completed. Thus, it is expected that an evaluation will have a number of abnormalities (see the definition in Clause 3). Historically, many abnormalities have not been reported with the test results because their significance was not clearly known. At the same time, not reporting abnormalities could be viewed as censoring of information by those who want the opportunity to form independent conclusions on the meaning of the results. The user may choose not to censor these failures, but they must be reported. The user may provide data analysis with or without these failures.

Abnormalities can be classified in four groups with respect to the effect on the outcome of the test.

- Class I. These result in immediate sample failure. (e.g., termination failure).
- Class II. These seriously affect the test outcome, but do not result in immediate sample failure (e.g. excessive temperature fluctuations).
- Class III. These have a minimal effect on the test outcome. (e.g., minor temperature fluctuations).
- Class IV. These are outliers (e.g., failures that are not expected or explainable).

Experience shows that the following abnormalities and corrective actions have occurred during past tank tests:

a) Class I (result in immediate sample failure)

Abnormalities

- Termination failure (includes stress cone)
- High-voltage connection failure
- Waterline failure
- Air failure
- Failure at cable support point

Corrective action options

- 1) Log failure as abnormality; reterminate (or splice); continue test; perform failure analysis; analyze to see if outlier.
- 2) Log failure as abnormality; reterminate (or splice); continue test.
- 3) Log as failure; replace with dummy sample; continue test.
- 4) Log failure as abnormality; remove sample and start new sample.
- 5) Analyze data to determine how long a “hot” connection may have been affecting aging conditions; then follow steps 1, 2, 3, or 4 above.
- 6) Log failure as abnormality; remove sample and start new sample; perform failure analysis; analyze to see if outlier.

b) Class II (seriously affect the test outcome)

Abnormalities

- Extended periods (>2 h) above or below temperature tolerance.
- Extended periods (>24 h) above or below voltage tolerance.
- Blocked conductor strands.

Corrective action options

- 1) Terminate test.
- 2) Adjust number of completed cycles, but do not change test days.
- 3) Quantify abnormality and report with results.

- 4) Remove sample and start new sample.
 - 5) Remove conductor blockage with pressure up to 2 atm (30 psi) with the cable at room temperature.
- c) Class III (minimal effect on the aging outcome)
- Abnormalities
- Tank water level outside tolerance
 - Short periods (<2 h) beyond temperature tolerance
 - Short periods (<24 h) beyond voltage tolerance
- Corrective action options
- 1) Log length and magnitude of abnormality
- d) Class IV (outliers)
- Abnormalities
- Very early (obvious) outlier. Less than 10% of expected mean, geometric mean or characteristic time to failure or mean breakdown strength.
 - Early outlier. Not obvious at first, but after data analysis, it is shown to be an outlier.
 - Late outlier (time to failure).
- Corrective action options
- 1) Analyze for cause. If cause found, replace with new sample.
 - 2) Analyze for cause. If cause found, replace with dummy sample.
 - 3) Analyze for cause. If cause not found, replace with new sample.
 - 4) Analyze for cause. If cause not found, replace with dummy sample.
 - 5) Outliers can be censored from data analysis (should be noted), but should not be censored from the reported data that accompanies data analysis.

13. Diagnostics

The following are commonly used evaluation techniques:

- Time to failure
- Fixed time of aging followed by ac dielectric strength
- Truncated population time to failure with ac dielectric strength on remaining samples

Other tests that may be used are impulse breakdown tests (Katz, et al., [B16]) and water tree counts (AEIC CS5-94, AEIC CS6-96).

When ac dielectric strength is a part of the evaluation, the breakdown strength of unaged cables should also be measured and the statistical parameters calculated. A five minute step test is commonly used (AEIC CS5-94, AEIC CS6-96) that starts at 4 kV/mm (100 V/mil) and increases in 1.6 kV/mm (40 V/mil) steps each five minutes. The 1.6 kV/mm (40 V/mil) step should be based on the design insulation wall thickness [e.g., a 4.4 mm (0.175 in) design wall equals 7 kV steps].

The ac breakdown test failures should be reported as previously described in Clause 11. This guide recommends the following information be reported on ac breakdown test failures:

- kV step in which failure occurred.

- Time between removal of tank test voltage from sample and start of voltage for ac breakdown test.
- Time between removal of sample from tank water and start of voltage for ac breakdown test.
- Thickness of insulation at point of failure.
- Location of failure along cable.
- Direction of failure

Although not widely used at present as a diagnostic technique in accelerated aging tests in the laboratory capacitance and/or tan delta measurements using power frequency or very low frequency (VLF) e.g., 0.1 Hz, are being actively considered for measurements on cables in the field (Kuschel, et al., [B17], Tharning, et al., [B27]). Capacitance and/or tan delta measurements could be employed as a diagnostic tool for aging tests in tanks although care should be taken to isolate the cable being measured from other cables in the tank. If such tests are being considered they should be performed at the start of the aging and at regular intervals during the aging. At least three voltage levels (e.g., $0.5 V_0$) up to the aging voltage, are recommended (Densley [B8]).

14. Data analysis

Failure data generated from the accelerated life test is often analyzed using a probability distribution such as Weibull or log normal (Abernathy [B2], Nelson [B22]). The log normal distribution should be considered if the fit with the Weibull distribution is poor (i.e., if the r^2 value of the regression of the Weibull distribution is <0.9).

Typically, most failures occur in the section of cable submerged in water (failure code W). However, some failures also occur at the water line (failure code WL), or in the air (failure code A). Any combination of these failure types may be included in the statistical analysis, but if the failure is not in the water, the information on “abnormality failure” given in Clause 12 should be used to report it. For example, a waterline, air, or termination failure should be reported when analyzing the data.

When reporting failure test results, it is very important to identify all failure types included in the data analysis. This is easily accomplished through the use of failure code(s) A, W, and WL.

It is also important to note that termination failures (failure code T) are usually not included in the statistical analysis. This is because the voltage stress is often much higher in the section of cable inside the termination. Additionally, the temperature gradient in the section of cable inside the termination is significantly influenced by the termination.

The Weibull analysis may be done manually, but it is recommended that a computer program be used for the calculations (Abernathy [B2], Nelson [B22]). The following information should be reported:

- a) The characteristic life (or scale parameter), referred to as η or α in the literature, and defined as the time or value at which 63.2% of the units have failed. It is usually calculated by a computer program, or can be read from the cumulative distribution function plot.
- b) The shape factor, usually given as β , and defined as the slope of the plotted line.
- c) The number of specimens tested and censored, if any.
- d) The two-sided 90% confidence limits for the entire set of failure times of the plotted line.
- e) The “goodness of fit.”
- f) The plot of the data.

The analysis should be reported as “complete” if all the specimens of the test population have failed and are included. The analysis should be reported as “censored” if some specimens have not yet failed, or if abnormalities are included. In the latter case it is essential that a computer program be used, and that the method of analysis giving the least bias in the results be used. Although the method of maximum likelihood

estimators (mle) is statistically correct and does handle the censored data case, it is best suited for sample sizes ≥ 50 . The method of linear regression (LR, X on Y) is the method that gives the least bias for data sets with small sample sizes (i.e., < 50). The general thinking is that LR is best for 80% of cases, and mle for 20%. Therefore it is important not to rule out the mle method, but LR should be the default method.

Many computer simulations for analyzing lifetime data with Weibull statistics exist. Some of these may be found in Abernathy [B2] and Nelson [B22].

15. Final report

The final report should contain all the important data about the test conditions and the results. An example of the typical information to be included is given in Annex A.

Although it is preferred that the test conditions be reported in full (e.g., $4 V_0$, 75°C and deionized water) they sometimes are reported in an abbreviated form. As the most important parameters are voltage magnitude, maximum temperature of the conductor in the water, and the water characteristics, these three parameters could be arranged as follows:

X/Y where X is the ratio of the test to the rated voltages, Y is the temperature in $^\circ\text{C}$. For example 4/75 would represent the test conditions of 4 times V_0 at 75°C . Alternatively the temperatures could be assigned digits for specific values (e.g., 45°C could be represented by 1, 60°C by 2, etc.). If salts are added to the water, the concentration in grams per liter could be included, for example 4/75/5 would represent $4 V_0$, 75°C and 5 g/l water solution.

16. Conclusions

The guide discusses the typical test parameters to be controlled in a tank test to accelerate the aging of medium-voltage extruded power cables due to water trees. It also describes techniques to control and measure these parameters.

Following the recommendations ensures that aging tests performed in different laboratories according to a specific set of aging conditions, will be conducted having well-controlled critical parameters and will result in the cables in the laboratories being subjected to the same test conditions. In addition, following the suggestions for the test specimens, preconditioning, and data analysis should also ensure a high degree of consistency in the data between laboratories. Unusual aging conditions that may affect the test results have been discussed along with relevant data to be included in a test report.

As more data are collected, it is anticipated that controversial issues discussed in this guide will be clarified in future editions. In addition it is hoped that in future editions specific test conditions such as voltage and temperature, can be recommended.

Annex A

(informative)

Final report

The following information should be included in the test report.

A.1 Test specimens

Table 1 of this guide gives information on the test specimens, cable construction, extrusion conditions, number of specimens to be tested, test specimen geometry, etc. The items in Table 1 should be included in the report, if they are available.

A.2 Prior tests and preconditioning

The report should contain the results of cable quality control tests and the details of the preconditioning tests. Any abnormalities, as described in Clause 12, should be included.

A.3 Test structure

A schematic of the tank layout should be given (see relevant clause of guide for examples). The details of the tank should be tabulated. A typical example is shown below.

Tank Details	
Length (mm)	
Width (mm)	
Height (mm)	
Side spacing (mm)	
End spacing (mm)	
Bottom spacing (mm)	
Sample spacing 1 (mm)	
Sample spacing 2 (mm)	
Water depth (mm)	
Tank material	
Tank insulation	
Insulation thickness (mm)	
Specimen mount	
Surface cover	

A.4 Temperature

The report should contain a figure indicating where the temperatures are measured in the test specimen and the water and also how it is controlled. A figure of the temperature profile showing the variation of temperature with time for startup and at least one stable temperature cycle should also be included. The maximum and minimum temperatures of the test specimen and the water should be tabulated, including tolerances. It is important to list any abnormalities, as described in Clause 12.

A.5 Water

The water characteristics, in the tank or in the cable conductors, and any properties measured (e.g., resistivity, pH, ion content, etc.) should be included. The frequency of monitoring the water (e.g., weekly, monthly, or quarterly) in each tank, the water/cable volume ratio and the tolerance on the water level, the water characteristics used to maintain the levels in the tank and cable conductors, and the use of water circulation in the tank should be stated. Any abnormalities in the condition of the water, either in the tank or in the cable conductor, should be listed.

A.6 Voltage

The amplitude and frequency of the voltage should be included along with the THD. Voltage interruptions, both scheduled and unscheduled, should be reported. Details of transients, if measured, should also be included along with any abnormalities, as described in Clause 12.

A.7 Results and data analysis

The data should be analyzed using the Weibull or log normal distributions and presented either graphically or in tabular form or both. The analysis should include the characteristic time-to-failure, the shape parameter, and the 90% confidence limits. Data excluded from the analysis due to an abnormality such as termination failure, etc., should be mentioned.

Annex B

(informative)

Bibliography

[B1] Abdolall, K., "Design of an Accelerated Aging Test for Polymer Insulated Distribution Cables," *Conference Record of 1990 IEEE Intl. Symp. Elect. Insul.*, Toronto, Canada, 1990, pp. 343–347.

[B2] Abernathy, R., "The New Weibull Handbook," Dr. R. Abernathy, 536 Oyster Road, North Palm Beach, FL 33408-4328, 1993.

[B3] Ashcraft, A., "Water Treeing in Polymer Dielectrics," *Kabelitems*, No. 152, 1979, pp. 5–11.

[B4] Banks, V. A. A., Faremo, H., and Steennis, E. F., "An Accelerated Aging Test on the Basis of 500 Hz for Water Treeing in Cables," *Proceedings Fourth International Conference on Insulated Power Cables (Jicable)*, June 25–29, 1995, pp.347–356.

[B5] Bartnikas, R., Densley, R. J., and Eichhorn, R. M., "Accelerated Aging Tests for Polymer Cables Under Wet Conditions," *IEEE Trans. on Power Delivery*, Vol. PWD-6, pp. 929–937, 1991.

[B6] Bartnikas, R., et al., "Accelerated Life Testing of Wet Cable Specimens at Frequencies above 60 Hz," *IEEE Trans. on Power Apparatus and Systems*, Vol. PAS-99, pp. 1575–1585, 1980.

[B7] Damon, D. H., Huang, S. J., and Johnson, J. F., "Electric Strength of XLPE Cable Insulation Containing Controlled Amounts of the Volatile Products of the Cross-linking Reaction," 1990 Ann. Rpt. *Conf. on Elect. Insul. and Diel. Phenom.*, 1990, pp. 398–404.

[B8] Densley, J., "Aging and Diagnostics in Extruded Insulations for Power Cables," *Fifth International Conference on Conduction and Breakdown in Solid Dielectrics*, 1995, pp. 1–15.

[B9] Eichhorn, R.M., "Organic Residues in Polyethylene Insulation Cross-linked with Dicumyl Peroxide," *Conf. Rec. 1972 IEEE Underground Trans. Conf.*, 1972, pp. 282–285.

[B10] EPRI Report EL-5387, "Characterization of Failed Solid-Dielectric Cables: Phase 2," Sept. 1987.

[B11] EPRI Report EL-5921, "Morphology of Extruded Dielectric Cable Insulation," 1988.

[B12] EPRI Report EL-7076 (RP 7897-01), "Evaluation of Sensitive Diagnostic Techniques for Cable Characterization," Dec. 1990.

[B13] EPRI Report TR-103908, "Effects of the Volatile By-Products of the Cross-linking Reaction on the Dielectric Strength of Cross-Linked Polyethylene Cables," July 1994.

[B14] EPRI Report TR-108405-V2 "Aging of Distribution Cables in Controlled Temperature Tank Tests," Aug. 1997

[B15] Hartlein, R., Harper, V. S., and Ng, H., "Effects of Voltage Surges in Extruded Dielectric Cable Life Project Update." *IEEE Trans. On Power Delivery*, Vol. PWD-8, No. 2, 1994, pp. 611–619.

[B16] Katz, C., Seman, G. W., and Bernstein, B. S., "Low Temperature Aging of XLPE and EP Insulated Cables with Voltage Transients." *IEEE Trans. on Power Delivery*, Vol. PWD-10, No. 1, 1995, pp. 34–42.

- [B17] Kuschel, Plath, R., Stepputat, I., and Kalkner, W., "Diagnostic Techniques for Service-Aged XLPE-Insulated Medium Voltage Cables." *Fourth International Conference on Insulated Power Cables, (Jicable)*, 25-29 June, 1995, pp.504–508, also published in REE, Special Issue, Vol.1, Aug.1996, pp.66–72.
- [B18] Luzzi, G. J., "Gas Pressure Build-up in Aluminum Conductor Cable," *IEEE Trans. on Power Apparatus and Systems*, Vol. 101, No. 6, 1982, pp. 1697–1699.
- [B19] Lyle, R., "Effect of Testing Parameters on the Outcome of Accelerated Cable Life Test," *IEEE Trans. on Power Delivery*, Vol. 3(2), 1988, pp. 434–439.
- [B20] Martin, M. A., and Hartlein, R. A., "Correlation of Electrochemical Treeing in Power Cables Removed from Service and in Cables Tested in the Laboratory," *IEEE Trans. on Power Apparatus and Systems*, Vol. PAS-99, 1980, pp. 1597–1605.
- [B21] Mashikian, M. S., et al., "Water-Treeing Propensity Tests of Materials and Cables in the United States," CIGRE Paper 15/21-02, 1992, 9 pp.
- [B22] Nelson, W., *Accelerated Testing*, John Wiley, 1990.
- [B23] Péliou, S., "Effect of water on the performance of XLPE insulation," Proceedings of the 3rd ICSD Conference, 1989, pp. 432–6.
- [B24] Schroth, R. G., Kalkner, W., and Fredrich, D., "Test Methods for Evaluating the Water Tree Behaviour of Extruded Cable Insulations," CIGRE Paper 15/21-01, 1990, 11pp.
- [B25] Srinivas, N. N., Bernstein, B. S., and Decker, R. A., "Effects of DC Testing on AC Breakdown Strength of XLPE Insulated Cables Subjected to Laboratory Accelerated Aging," *IEEE Trans. On Power Delivery*, Vol. PWD-5, No. 4, 1990, pp. 1643–1651.
- [B26] Steennis, E. F., and Faremo, H., "State of the Art of Water Tree Testing on Cables—The Development of an Accelerated Aging Test," CIGRE Paper 15/21-03, 1992, 12 pp.
- [B27] Tharning, P., et al., "High Voltage Dielectric Response Analyser for Cable Diagnostics," 1993 Ann. Rpt. *Conf. on Elect. Insul. and Diel. Phenom.*, 1993, pp. 398–404.
- [B28] UNIPEDE-DISCAB, "International Cable Fault Statistics on Synthetically Insulated MV Cables," *CIREN Conf.*, Vol. 1, 1989, pp. 200–206.
- [B29] Walton, M. D., Smith, J. T., and Thue, W. A., "Accelerated Aging of Extruded Dielectric Power Cables, Part 1: Control and Monitoring Methodology," *IEEE Trans on Power Delivery*, Vol. 7(2), 1992, pp. 596–602.
- [B30] Wartusch, J., and Wagner, H., "About the Significance of Peroxide Decomposition Products in XLPE Cable Insulation," Proc. 1976 *IEEE Intl. Symp. Elect. Insul.*, Montreal, Canada, 1976, pp. 219–223.